

## Food & Pharmaceutical

Technology, Market and Applications



# Products and Components



You've got the Application, we've got the Solution

**Within the Business Unit Pumps & Systems, Food & Pharmaceutical holds a crucial position all over the world with regard to uncompromising hygiene and most demanding process requirements in all manufacturing areas.**

## **Business Field Food & Pharmaceutical**

- Beverages
- Breweries
- Milk industry
- Wine
- Biotechnology
- Cosmetics
- Pharmaceuticals
- Fish
- Fruits
- Starch
- Sugar
- And similar

## **We are where you are**

With worldwide more than 1,400 employees at six development and production sites as well as 25 sales offices, a cooperation partner and another 200 NETZSCH representatives we are close to you wherever you are.

## Product Range

### **NEMO® Progressing Cavity Pumps**

- Hygienic pumps
- Hygienic mini pumps
- Aseptic pumps

### **TORNADO® Rotary Lobe Pumps**

- Hygienic rotary lobe pumps

### **NETZSCH Accessories**

- Protection devices
- Flushing/sealing pressure devices
- Control systems
- Trolley assemblies
- Tools

## **We have our Finger on the Pulse**

Products should keep fresh for a longer period of time but still maintain their original quality standard. Our pumps as the „driving force“ in your production process are a key ingredient of your product quality.

We develop, manufacture and sell positive displacement pumps which ensure in all process stages a hygienic and smooth conveyance of high quality and shear-sensitive fluids.

## **Driving Forces**

Two different types of pumps are available for various process requirements: NEMO® hygienic and aseptic progressing cavity pumps and NETZSCH TORNADO® hygienic rotary lobe pumps. For each application your pump is individually laid out for you.

## **Engineering Partnerships**

With our customers from all over the world we are able to incorporate the latest market trends and requirements into the development and improvement of our products. Therefore new possibilities for your manufacturing process continually arise.

# NEMO® Hygienic and Aseptic Progressing Cavity Pumps

## Characteristics and Typical Components

**The hygienic design of components and machinery as well as the cleanability of process plants are defined in a multitude of rules and regulations.**

NEMO® pumps are constructed, manufactured and tested according to EHEDG regulations (European Hygienic Equipment Design Group) or QHD regulations (Qualified Hygienic Design). The materials used are certified in accordance with FDA (Food and Drug Administration).

Additionally, NEMO® hygienic and aseptic progressing cavity pumps are certified according to the 3-A Sanitary Standards of the US and GOST-R (Russian Certificate of Conformity).

### Large Range of Capacities and Pressures

- Flow rates from a few ml/h up to 140 m<sup>3</sup>/h
- Pressures up to 24 bar

### Wide Range of Applications

NEMO® hygienic and aseptic progressing cavity pumps are normally used for fluids having the following properties:

- Shear-sensitive
- Of low up to high viscosity
- Smearing and non-smearing
- With or without solids
- Dilatant or thixotropic
- Abrasive
- Adhesive

### Advantages

- Smooth delivery
- Long process cycles due to contamination proof design
- Suitable for CIP and SIP
- Almost pulsation-free conveyance
- Flow rate in proportion to speed with high dosing accuracy over a wide speed range
- Flow rate independent of variances in pressure or viscosity
- Product intake possible in vacuum conditions up to almost total vacuum
- The crevice free housing designed for good flow condition avoids settling of the fluid
- Hopper shaped stator inlet for optimal filling of the conveying chambers
- All contact surfaces in polished version to avoid caking of the fluid and to facilitate cleaning
- For lubricating fluids, open, patented, hygienic joints
- Version with flexible rod for uncompromising hygiene and long serviceable life
- Elastomers in food standards according to FDA
- Heating of housing and stator (optional)
- Horizontal or vertical installation
- Service friendly

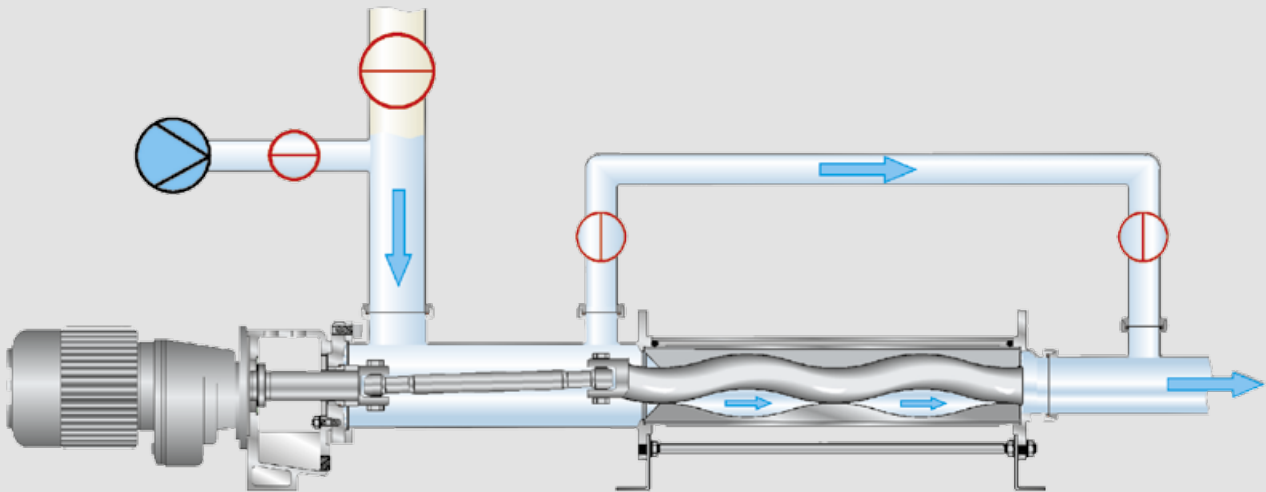



## CIP/SIP Process

For the CIP process, the entire system requires a cleaning fluid velocity of at least 1.5 m/s and to facilitate this the NEMO® hygienic and aseptic progressing cavity pumps are equipped with additional cleaning ports. The position of these ports can be determined to suit the application and they require a bypass pipe.

The bypass is also required for the SIP process. In both the CIP and SIP processes the NEMO® pumps are operated intermittently.

Tangential cleaning ports guarantee complete emptying of the NEMO® pump. All pump materials used are suitable for CIP and SIP processes.

-  CIP pump
-  CIP medium
-  valve open
-  valve closed

# NEMO® Hygienic Pump in Block Construction Design

## Characteristics and Typical Components



### Flexible Rod

The flexible rod for universal use in the NEMO® Hygienic Plus series is corrosion-proof, crevice free, wear and maintenance free because there are no components moving against each other as in other joint types. Neither lubrication nor seals are required so that the lubricity of the fluid does not have to be taken into consideration. Ideal for pumping highly sensitive products with or without solids and for uncompromising hygienic applications.

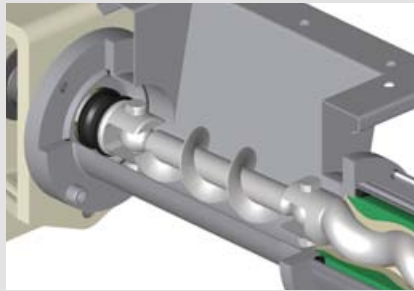

### Feeding Screw Hopper

For highly viscous and pasty products, the pump is optionally equipped with a feeding screw and a hopper to allow for an optimal filling of the conveying chambers.



### Heating Rail and Thermal Jacket

Optional version with pump housing and stator which can be heated or cooled.

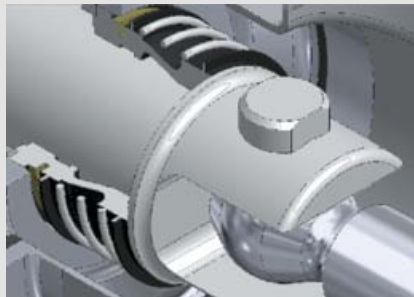

### Mechanical Seal with Elastomer Bellows (standard)

Single seal, unbalanced, independent of direction of rotation, elastomere bellows with or without knife edge. Seals in SIC. On request elastomere in compliance with FDA standards.

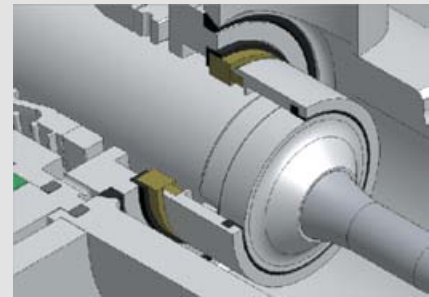

### Mechanical Seal with Spring (optional)

Single seal, balanced, independent of direction of rotation, with product protected spring. Smooth surface. Seals in SIC. Elastomere in compliance with FDA standards.

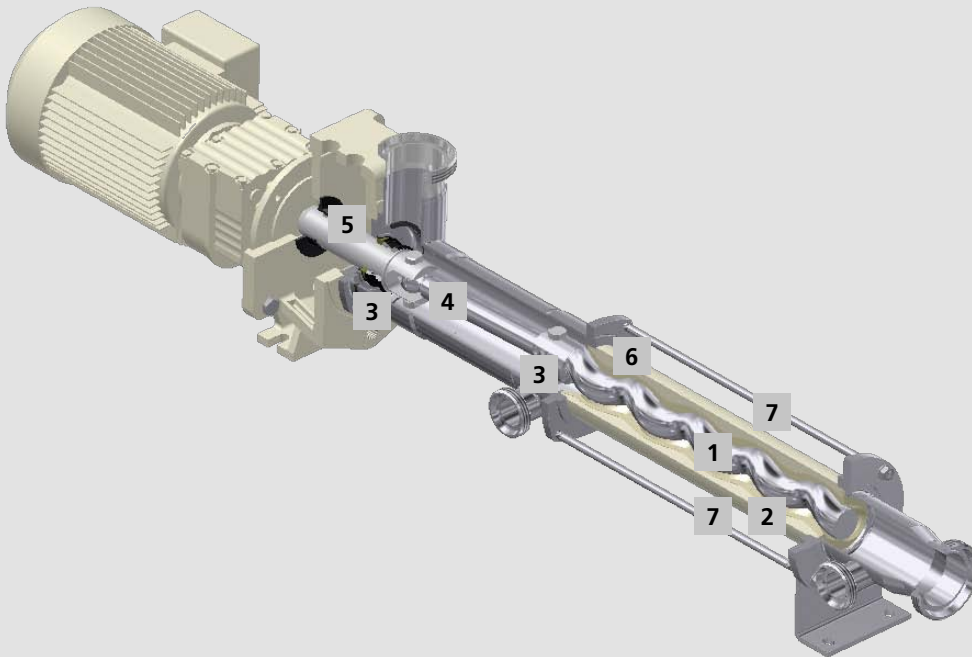

**1 Rotor**

In stainless steel.

**2 Stator with Reduced Wall Thickness**

For changing product temperatures a patented stator with reduced elastomer wall thickness is used. In addition, a thermal stator protector (STP-2 or STP-D) for overheating and dry running protection is available.

**3 Hygienic Joints**

Patented, open crevice free hygienic joints for optimal cleaning.

**4 Drive Chain**

Drive and connection shaft with coupling rod and two hygienic joints for drive transmission to the rotor.

**5 Sealing Housing**

Various shaft sealings are available.

**6 Stator Jacket**

In stainless steel (optional).

**7 Stator Bolts**

In stainless steel.

# NEMO® Aseptic Pump with Bearing Housing

## Characteristics and Typical Components



### Flexible Rod

The flexible rod for universal use in the NEMO® Hygienic Plus series is corrosion-proof, crevice free, wear and maintenance free because there are no components moving against each other as in other joint types. Neither lubrication nor seals are required so that the lubricity of the fluid does not have to be taken into consideration. Ideal for pumping highly sensitive products with or without solids and for uncompromising hygienic applications.

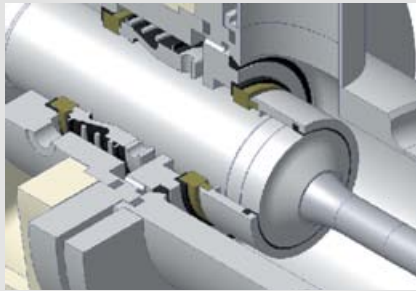

### Double Mechanical Seal in Tandem Arrangement

Double mechanical seal in tandem arrangement with unpressurized, static or dynamic quench. Mechanical seals in SIC. Elastomer in compliance with FDA standards. The design of the rotating unit guarantees the seal integrity at changing temperatures and pressures. The seal complies with EHEDG and QHD regulations.

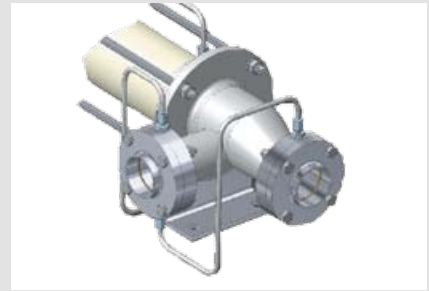

### Pipework (optional)

The pipework circulates sterile condensate, vapour and/or detector fluid to the double acting, closed seal lines.



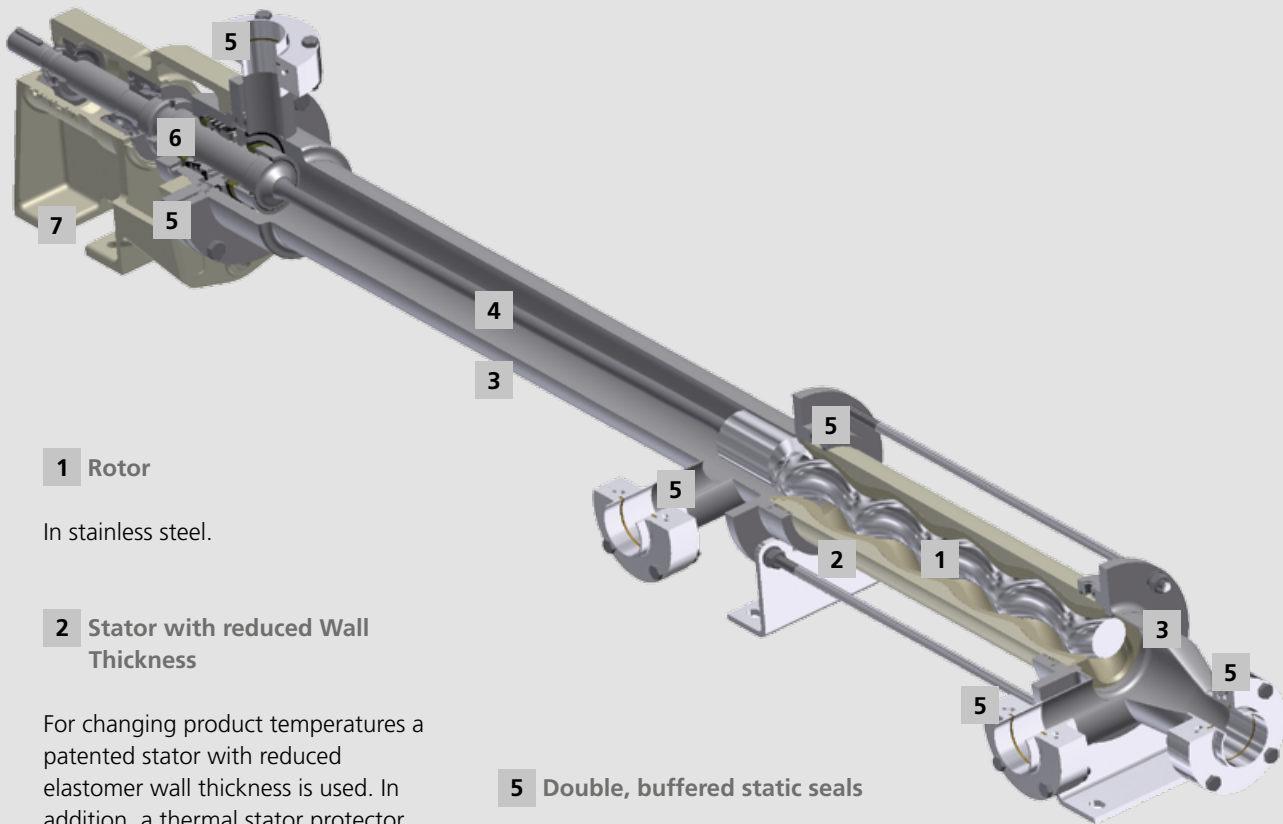

## 1 Rotor

In stainless steel.

## 2 Stator with reduced Wall Thickness

For changing product temperatures a patented stator with reduced elastomer wall thickness is used. In addition, a thermal stator protector (STP-2 or STP-D) for overheating and dry running protection is available.

## 3 Housing/Discharge Flange

The pump housing has a reduced diameter for optimal flow velocity and minimized pump volume. The body flange is located directly above the shaft seal removing any dead flow areas. Therefore the deposit of fluid in the housing during the manufacturing cycle is eliminated.

## 4 Flexible Rod

## 5 Double, buffered static seals

All static seals to the atmosphere are double sealed chambers. Sterile condensate, vapour and/or detector fluid is continuously supplied to the chambers. Through the contamination-proof design the process cycle can be reduced by the removal of some sterilization processes. Consequently output capacity increases as the number of cleaning cycles decreases.

## 6 Sealing Housing

Double mechanical seal in tandem arrangement with unpressurized, static or dynamic quench.

## 7 Bearing Housing

Widely spaced, heavy duty bearings ensure optimum concentricity of the drive shaft and are able to withstand large axial loads. The free shaft end allows for the use of all types of drive.

# NETZSCH TORNADO® Hygienic Rotary Lobe Pump

## Characteristics and Typical Components

The hygienic design of components and machinery as well as the self-draining cleanability of parts of a plant are defined in a multitude of rules and regulations.

### CIP-/SIP-Process

For the CIP process, in the whole system the cleaning fluid should have a flow velocity of at least 1.5 m/s, thus, NETZSCH TORNADO® hygienic rotary lobe pumps may also be used as cleaning pumps, i.e. delivery and cleaning with the same pump. All materials are in line with CIP and SIP processes.

### Large Range of Capacities and Pressures

- Flow rates up to 150 m<sup>3</sup>/h
- Pressures up to 12 bar

### Wide Range of Applications

NETZSCH TORNADO® hygienic rotary lobe pumps are normally used for fluids having the following properties:

- Shear sensitive
- With or without solids
- Medium up to high viscosity (300 mPas to 100.000 mPas)
- Thixotropic and dilatant
- Lubricating and non lubricating
- Adhesive

### Advantages

- Compact design, high performance
- Suitable for a wide temperature range
- Resistant to dry running
- Smooth delivery
- Flow rate in proportion to speed
- Direction of rotation, thus, direction of flow reversible
- Vibration free and quiet running
- Capable of CIP and SIP
- Enlarged inlet cross section for highly viscous fluids (optional)
- Easy maintenance of the conveying elements and shaft seal without having to remove the pump from the pipe

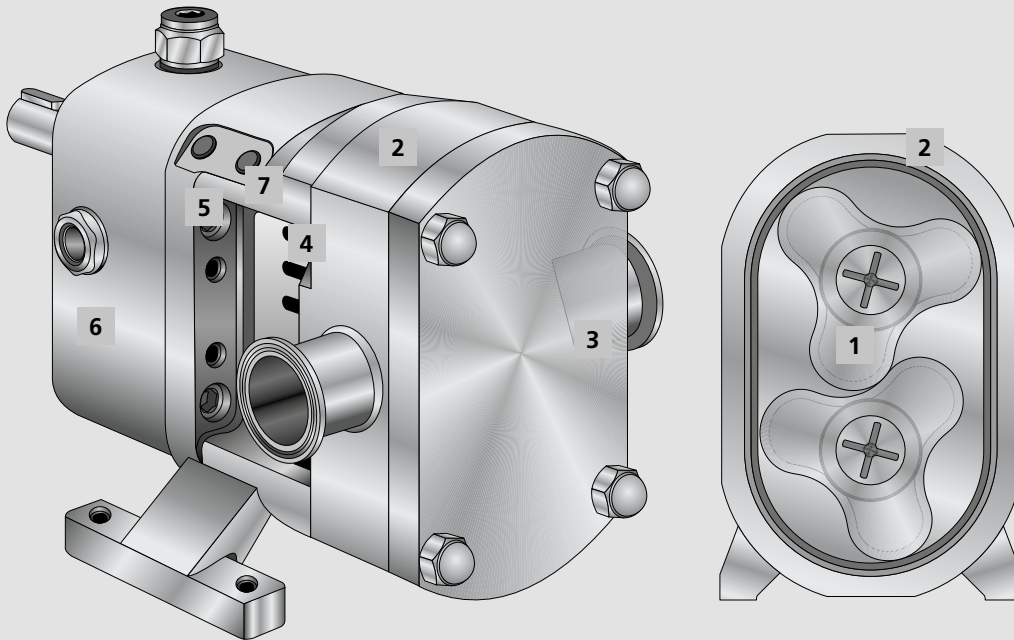

## 1 Rotary Lobes

Depending upon the application, three and four wing lobes are used as rotating elements.

## 2 Pump Housing

Product inlet ports are designed for good flow conditions. Better flow into the rotary lobes. Pump connections horizontally or vertically positioned for complete emptying.

The housing connection is mounted directly above the mechanical seal removing any dead areas and thereby avoiding sedimentation in the housing during the production cycle.

## 3 Housing Cover Plate

Rotary lobe and shaft seal are easily accessible through the housing cover and can be maintained or exchanged without having to remove pump housing or gears.

## 4 Shaft Seal

Standard design is with single acting mechanical seal independent of the direction of rotation. On request various types of single/double acting mechanical seals, special seals, as well as stuffing boxes are available.

## 5 Timing Gear

The helical gears allow for precise positioning of the rotary lobes and guarantee quiet running.

## 6 Gear Housing

Gear housing completely made from stainless steel and is easily disassembled.

## 7 Bearings

Tapered roller bearings ensure a high concentricity tolerance and load bearing capability.

The NETZSCH Group is an owner-managed, internationally operating technology company headquartered in Germany.

The three Business Units – Analyzing & Testing, Grinding & Dispersing and Pumps & Systems – provide tailored solutions for highest-level needs. Over 2,300 employees at 130 sales and production centers in 23 countries across the globe guarantee that expert service is never far from our customers.

The NETZSCH Business Unit Pumps & Systems offers NEMO® progressing cavity pumps, TORNADO® rotary lobe pumps, screw pumps, macerators/grinders, dosing systems and equipment custom built and challenging solutions for different applications on a global base.

NETZSCH Mohnopumpen GmbH  
Business Field Food & Pharmaceutical  
Geretsrieder Straße 1  
84478 Waldkraiburg  
Germany  
Tel.: +49 8638 63-1030  
Fax: +49 8638 63-2358  
info.nmp@netzsch.com

[www.netzsch.com](http://www.netzsch.com)